



ScanDome™ II Housing

Features

- ▶ HSGN-502
 - Pendant type Indoor housing for ScanDome™ II
- ▶ HSGN-502SH
 - Pendant type outdoor housing with sun shield, fan & heater for ScanDome™ II
- ▶ HSG-502F
 - Flush type indoor housing for ScanDome™ II



HSGN-502 HSGN-502SH HSG-502F

HSGN-502, HSGN-502SH, HSG-502F

Technical Information

Model		HSGN-502/HSGN-502SH
Mechanical	Material	Aluminum & Steel
	Max. Load	2Kg
	Finish	Light-gray Polyester Powder Coat
	Weight	3,5Kg
Electrical	Power	AC24V
	Power	35Watt (for Fan & Heater)
	Consumption	55Watt (for Fan & Heater + Dome)

Model		HSG- 502F
Dimensions	φ 220 x 135 (H) mm	
Weight	500g	
Max. Load	2kg	
Operating Temperature	-10℃ ~ 50℃ (Indoor)	
Operating Humidity	0 ~ 100%	
Material	Steel & Molded plastic	

Dimensions & Connections

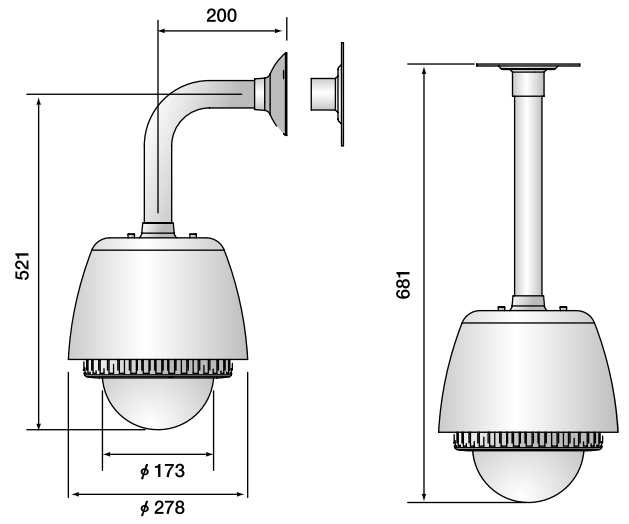

(Unit : mm)

